

	wheel dia.	tread width	hub width	bore dia.	load cap.	tread style	ply rating	max. psi	plain bore	roller bearing	ball bearing
P	220	65	66	20	80	patterned	4	30	PTW 8-20	PTW 8-20RB	
P		65	66	25	80	patterned	4	30	PTW 8-25	PTW 8-25RB	
P		65	66	1"	80	patterned	4	30	PTW 8-1	PTW 8-1RB	
P	260	85	66	20	120	patterned	4	30	PTW 10-20	PTW 10-20RB	
P		85	66	25	120	patterned	4	30	PTW 10-25	PTW 10-25RB	
P		85	66	1"	120	patterned	4	30	PTW 10-1	PTW 10-1RB	
P	300	100	66	20	150	patterned	4	30	PTW 12-20	PTW 12-20RB	
P		100	66	25	150	patterned	4	30	PTW 12-25	PTW 12-25RB	
P		100	66	1"	150	patterned	4	30	PTW 12-1	PTW 12-1RB	
P	355	100	66	20	185	patterned	4	30	PTW 14-20	PTW 14-20RB	
P		100	66	25	185	patterned	4	30	PTW 14-25	PTW 14-25RB	
P		100	66	1"	185	patterned	4	30	PTW 14-1	PTW 14-1RB	
P	400	100	66	20	200	ribbed	4	30	PTW 16-20	PTW 16-20RB	
P		100	66	25	200	ribbed	4	30	PTW 16-25	PTW 16-25RB	
P		100	66	1"	200	ribbed	4	30	PTW 16-1	PTW 16-1RB	
P		100	83	1"	200	ribbed	4	30			PTW 16-1BB *

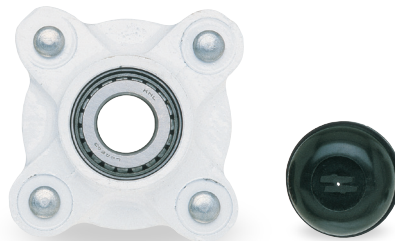

i * Ball bearing wheel has black centre

	wheel dia.	tread width	hub width	bore dia.	load cap.	ply rating	max. psi	wheel without hub	wheel with hub	hub only c/w cap
P	410	107	-	-	265	4	60	VRW 16-4		
P		107	see drawing		265	4	60		VRW 16-1TM4	
P		107	-	-	335	6	70	VRW 16-6		
P		107	see drawing		335	6	70		VRW 16-1TM6	
P	-	-	see drawing	-	-	-	-			HUBTM1

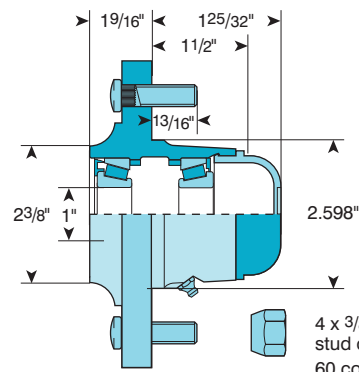

P Preferred range product, see page 1 for details

i All dimensions are in mm and all loadings are in kg unless otherwise stated